

KITZ

GENERAL CATALOG

Carbon Steel

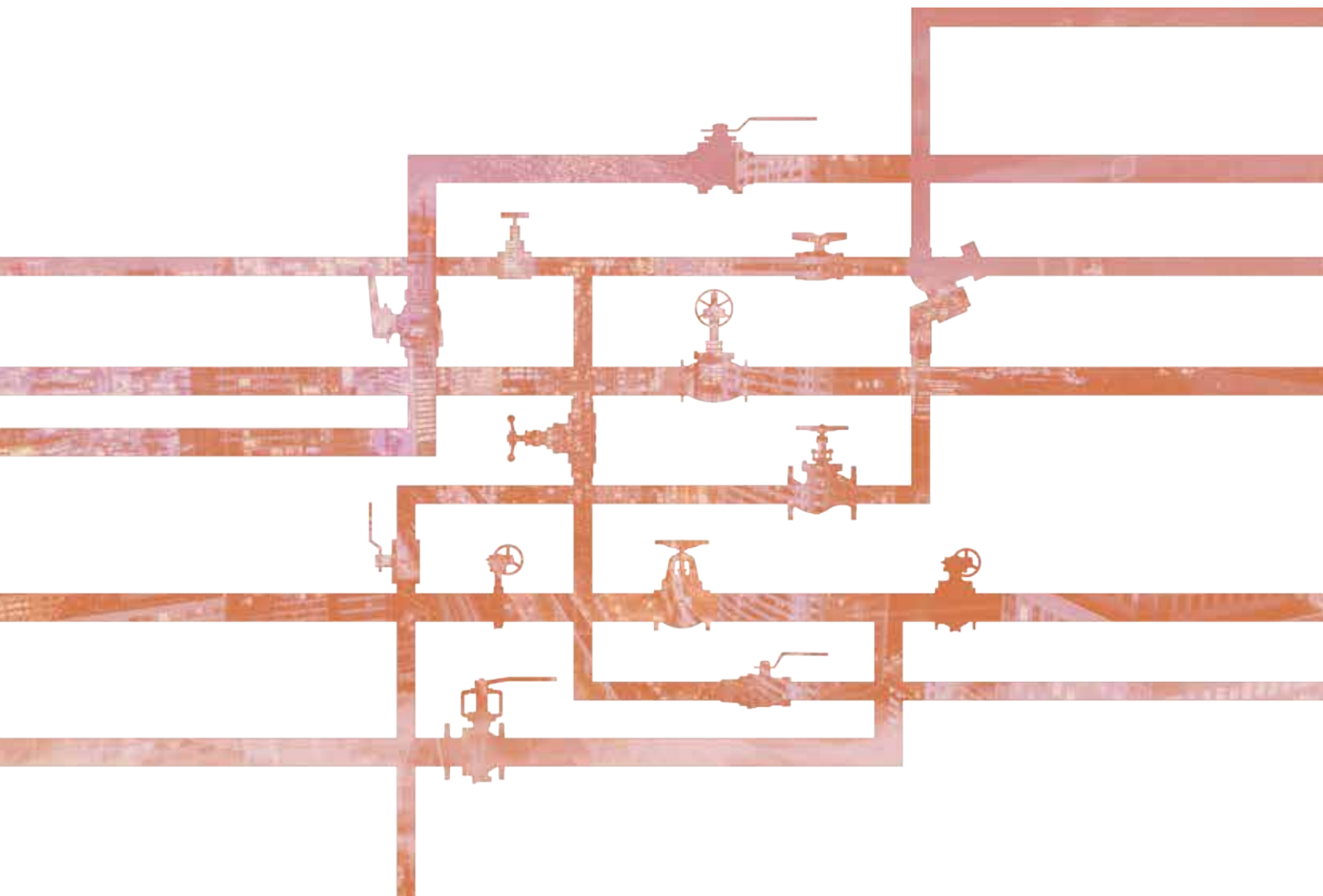

INDEX

Title	Body Material	Type	Class	End Connection	Features/Design	Size Range	Fig	Page	
Carbon Steel Valves (Bolted Bonnet/ Bolted Cover, Outside Screw & Yoke)	CS	Gate	150	FE/RF		API 600/ISO 10434	1 1/2 ^B - 36 ^B	150SCLS/G-150SCLS 300SCLS/G-300SCLS 600SCLS/G-600SCLS 900SCLS/G-900SCLS 1500SCLS/G-1500SCLS	CS3 242
			300				2 ^B - 24 ^B		
			600						
			900						
		1500	Globe			150	BS 1873	1 1/2 ^B - 18 ^B	150SCJS/G-150SCJS 300SCJS/G-300SCJS 600SCJS/G-600SCJS 900SCJS/G-900SCJS 1500SCJS/G-1500SCJS
		300				1 1/2 ^B - 16 ^B			
		600				2 ^B - 12 ^B			
		900				3 ^B - 8 ^B			
		1500				2 ^B - 8 ^B			
		Check	150			Swing	BS 1868	1 1/2 ^B - 30 ^B	150SCOS
			300			Swing, Internal Hinge Pin	API 594	1 1/2 ^B - 18 ^B	150SCOHS
						Swing	BS 1868	1 1/2 ^B - 30 ^B	300SCOS
			600			Swing, Internal Hinge Pin	API 594	1 1/2 ^B - 16 ^B	300SCOHS
						Swing	BS 1868	2 ^B - 24 ^B	600SCOS
			900			Swing, Internal Hinge Pin	API 594	2 ^B - 12 ^B	600SCOHS
						1500	Swing	BS 1868	3 ^B - 20 ^B
2 ^B - 16 ^B	1500SCOS								
Carbon Steel Valves (Pressure Seal Bonnet/Pressure Seal Cover, Outside Screw & Yoke)	Gate	900	FE/RF or BW		ASME B16.34	2 ^B - 24 ^B	(G-)(W)900SCLSPSY	CS5 244	
		1500					(G-)(W)1500SCLSPSY		
		2500					(G-)(W)2500SCLSPSY		
	Globe	900					(G-)(W)900SCJSPSY	CS6 245	
		1500					(G-)(W)1500SCJSPSY		
	2500	Check					900	(G-)(W)2500SCJSPSY	
							1500	(W)900SCOSPSY	
	2500	Swing						(W)1500SCOSPSY	
								(W)2500SCOSPSY	

* (Abbreviation) FE: Flanged Ends, RF: Raised Face Ends, BW: Butt welding Ends

CS

Carbon Steel

PRODUCT CODING

Carbon & Low Alloy Steel Valves

(Note: Some products do not follow this coding system)

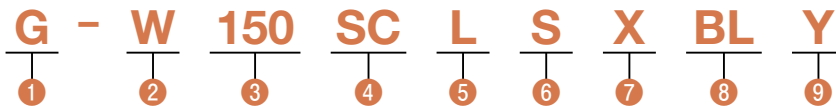

1 Operation

- None Manual Handwheel
- G Gear

2 End Connection

- None Raised Face Flanged Ends
- W Buttweld Ends

3 Pressure Class

- 10 10K
- 20 20K
- 150 Class 150
- 300 Class 300
- 600 Class 600
- 900 Class 900
- 1500 Class 1500
- 2500 Class 2500

4 Shell Material Code

- SC Carbon/Low Alloy

5 Valve Type

- L Gate
- J Globe
- O Swing Check
- OH Internal Hinge Pin Swing Check

6 Body Seat Ring

- S Mounted on Body by Seal Welding.
Class 900/1500 Globe Valves are Integral Seat Type

7 Special Design

- None Standard
- PS Pressure Seal Bonnet/Cap
- X -46°C service

8 Shell Material

- None A216 WCB/WCC
- WC6 A217 WC6
- WC9 A217 WC9
- C5 A217 C5
- C12 A217 C12
- LCB A352 LCB
- LCC A352 LCC

9 Body/Disc Seat Surface Material

- None Body Seat Surface Hard Face
- Y Body/Body Seat Surfaces both Hard Faced

Design Specification

Carbon & Low Alloy Steel Valves

Shell Wall Thickness & General Valve Design	API 600/ISO 10434 (Gate) BS1873 (Globe) BS 1868/API594*1 (Swing Check)
P-T Rating	ASME B16.34 (JIS B2220 for 10K & 20K)
Face to Face Dimension	ASME B16.10 (JIS B2002 for 10K & 20K)
Flanged Ends Dimension	ASME B16.5*2/MSS SP-44 (22 ^B)/ASME B16.47 Series B (26 ^B & above) (JIS B2220 for 10K & 20K)
Buttweld Ends Dimension	ASME B16.25, ISO10434 (Gate), BS1873 (Globe)/1868 (Check)
Pressure Test	API 598/ISO 5208
Fugitive Emission Test (Up to Class 600)	API 624/ISO 15848-1
Cryogenic/Low Temperature Test*3	ISO 28921-1

*1 API 594 is for Internal Hinge Pin Check Valves (except 11/2^B)



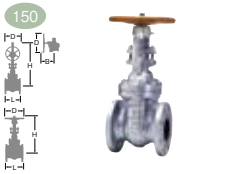
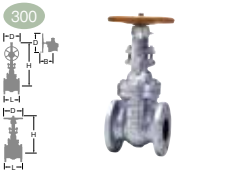
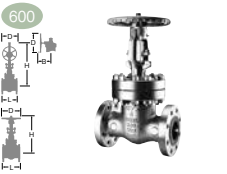
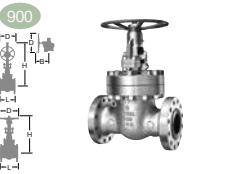

*2 Pipe Connection Dimensions shall be indicated in millimeters converted from dimensions in inches according to ASME B16.5

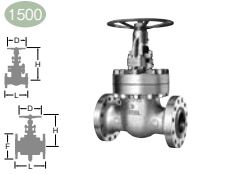
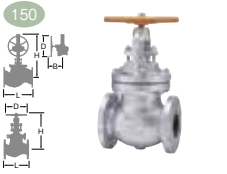
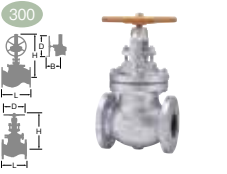
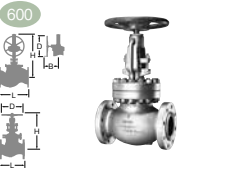
*3 For X (Low Temperature Service Valves)

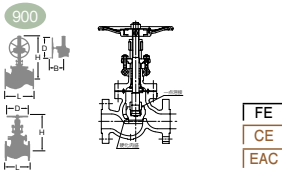
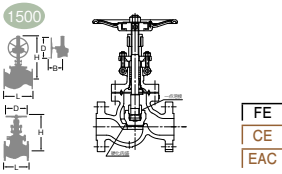
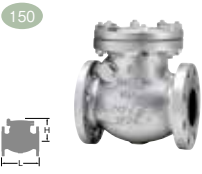
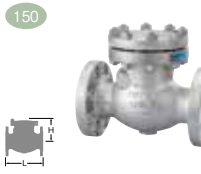
Type	Gate				Gate				Gate				Gate				
Carbon & Low Alloy Steel Valves (GGC)																	
	API600 FE CE EAC				API600 FE CE EAC				API600 FE CE EAC				API600 FE CE EAC				
Fig	150SCLS/G-150SCLS				300SCLS/G-300SCLS				600SCLS/G-600SCLS				900SCLS/G-900SCLS				
End Connection	ASME B16.5 Class 150 RF*				ASME B16.5 Class 300 RF*				ASME B16.5 Class 600 RF*				ASME B16.5 Class 900 RF				
inch	mm	L	H	D	B	L	H	D	B	L	H	D	B	L	H	D	B
11/2	40	165	385	200		190	414	200		292	446	200		368	520	250	
2	50	178	385	200		216	414	200		330	497	250		381	621	300	
21/2	65	190	432	200		241	457	200		356	545	250		457	706	350	
3	80	203	509	250		283	531	250		432	667	300		610	900	500	
4	100	229	592	250		305	618	250		559	893	450		737	1087	600	
5	125	254	658	300		381	694	300		660	1094	500		838	1285	680	
6	150	267	758	300		403	794	350		838	1464	680		1029	1714	600	456
8	200	292	958	350		419	1015	400		889	1593	760		1130	1830	600	TBA
10	250	330	1162	400		457	1216	450		991	1779	760		1219	2180	600	TBA
12	300	356	1362	450		502	1458	600		1092	2070	910		1321	2435	610	TBA
14	350	381	1572	600		562	1654	600		1295	2500	600	456				
16	400	406	1692	600		618	1767	680		1397	2730	610	417				
18	450	432	1888	600		680	1933	680									
20	500	457	2123	680		741	2137	760									
22	550	483	2326	680		802	2364	760									
24	600	508	2498	760		863	2544	910									
26	650	559	2835	500	280	1245	2848	600	350								
28	700	610	3022	600	350	1346	3151	600	456								
30	750	610	3154	600	350	1397	3341	600	456								
32	800	660	3267	600	350	1524	3650	600	456								
34	850	711	3507	600	350	1626	3826	600	456								
36	900	711	3785	600	456	1727	3926	600	456								
Body/Bonnet	WCB				WCB				WCB				WCB				
Stem	F6a				F6a				F6a				F6a				
Disc	13Cr or Carbon Steel+13Cr				13Cr or Carbon Steel+13Cr				13Cr or Carbon Steel+13Cr				13Cr or Carbon Steel+13Cr				
Body Seat Ring	Carbon Steel+HF				Carbon Steel+HF				Carbon Steel+HF				Carbon Steel+HF				
Gland Packing	Flexible Graphite				Flexible Graphite				Flexible Graphite				Flexible Graphite				
Gasket	Refer to Page CS9				Refer to Page CS9				Refer to Page CS9				Refer to Page CS9				
Bonnet Bolt/Nut	B7/2H				B7/2H				B7/2H				B7/2H				
P-T Rating	ASME B16.34				ASME B16.34				ASME B16.34				ASME B16.34				
F-to-F Dimension	ASME B16.10				ASME B16.10				ASME B16.10				ASME B16.10				
Wall Thickness	API 600				API 600				API 600				API 600				
Approval	ISO15848-1 API 624, PED/CE TR-CU/EAC				ISO15848-1 API 624, PED/CE TR-CU/EAC				ISO15848-1 API 624, PED/CE TR-CU/EAC				ISO15848-1 API 624, PED/CE TR-CU/EAC				
Remarks	Flexible Wedge, *MSS SP-44 (22 nd)/ ASME B16.47 Series B (26 th & above)				Flexible Wedge, *MSS SP-44 (22 nd)/ ASME B16.47 Series B (26 th & above)				Flexible Wedge, *MSS SP-44 (22 nd)/ ASME B16.47 Series B (26 th & above)				Solid Wedge ≤4 th , Flexible Wedge ≥ 6 th				



Type	Gate				Globe				Globe				Globe				
Carbon & Low Alloy Steel Valves (GGC)																	
	API600 FE CE EAC				API600 FE CE EAC				API600 FE CE EAC				API600 FE CE EAC				
Fig	1500SCLS/G-1500SCLS				150SCJS/G-150SCJS				300SCJS/G-300SCJS				600SCJS/G-600SCJS				
End Connection	ASME B16.5 Class 1500 RF				ASME B16.5 Cassl 150 RF				ASME B16.5 Class 300 RF				ASME B16.5 Class 600 RF				
inch	mm	L	H	D	B	L	H	D	B	L	H	D	B	L	H	D	B
11/2	40					165	331	200		229	362	200		292	406	250	
2	50	368	559	250		203	331	200		267	362	200		330	474	300	
21/2	65	419	635	300		216	380	250		292	428	250		356	508	350	
3	80	470	685	350		241	390	250		318	436	250		432	597	500	254
4	100	546	772	400		292	459	250		356	510	350		508	930	500	280
5	125					356	485	300		400	608	400		559	993	500	280
6	150	705	1031	600		406	513	350		444	989	500	254	660	1121	600	350
8	200	832	1248	680		495	929	500	280	559	1064	500	280	787	1420	610	417
10	250	991	1475	910		622	975	500	280	622	1142	600	350	838	1575	610	417
12	300	1130	1656	910		698	1049	500	280	711	1187	600	350				
14	350	1257	1750	600	TBA	787	1106	500	280	838	1766	680	350				
16	400	1384	2060	610	TBA	914	1224	600	350	864	1932	680	350				
18	450					978	1275	600	TBA								
Body/Bonnet	WCB				WCB				WCB				WCB				
Stem	F6a				403SS				403SS				403SS				
Disc	13Cr or Carbon Steel+13Cr				13Cr or Carbon Steel+13Cr				13Cr or Carbon Steel+13Cr				13Cr or Carbon Steel+13Cr				
Body Seat Ring	Carbon Steel+HF				Carbon Steel+HF				Carbon Steel+HF				Carbon Steel+HF				
Gland Packing	Flexible Graphite				Flexible Graphite				Flexible Graphite				Flexible Graphite				
Gasket	Refer to Page CS9				Refer to Page CS9				Refer to Page CS9				Refer to Page CS9				
Bonnet Bolt/Nut	B7/2H				B7/2H				B7/2H				B7/2H				
P-T Rating	ASME B16.34				ASME B16.34				ASME B16.34				ASME B16.34				
F-to-F Dimension	ASME B16.10				ASME B16.10				ASME B16.10				ASME B16.10				
Wall Thickness	API 600				API 623				API 623				API 623				
Approval	ISO15848-1 API 624, PED/CE TR-CU/EAC				ISO15848-1 API 624, PED/CE TR-CU/EAC				ISO15848-1 API 624, PED/CE TR-CU/EAC				ISO15848-1 API 624, PED/CE TR-CU/EAC				
Remarks	Solid Wedge ≤4 th , Flexible Wedge ≥ 6 th																

Type	Globe				Globe				Swing Check			Swing Check			
Carbon & Low Alloy Steel Valves (GGC)															
	900SCJS/G-900SCJS				1500SCJS/G-1500SCJS				150SCOS			150SCOHS			
Fig	900SCJS/G-900SCJS				1500SCJS/G-1500SCJS				150SCOS			150SCOHS			
End Connection	ASME B16.5 Class 600 RF				ASME B16.5 Class 1500 RF				ASME B16.5 Cassl 150 RF*			ASME B16.5 Cassl 150 RF			
inch	mm	L	H	D	B	L	H	D	B	L	H	D	L	H	D
11/2	40									165	132		165	132	
2	50					368	557	350		203	156		203	156	
21/2	65					419	920	500	TBA	216	168		216	168	
3	80	381	900	500	254	470	969	500	332	241	185		241	185	
4	100	457	957	500	280	546	1092	600	417	292	210		292	210	
5	125									330	239				
6	150	610	1173	600	350	705	1336	600	456	356	250		356	250	
8	200	737	1381	600	456	832	1400	610	TBA	495	293		495	293	
10	250									622	340		622	340	
12	300									698	377		698	375	
14	350									787	415		787	415	
16	400									864	455		864	455	
18	450									978	508		978	508	
20	500									978	585				
24	600									1295	670				
26	650									1295	740				
28	700									1448	810				
30	750									1524	871				
Body/Bonnet/Cover	WCB				WCB				WCB			WCB			
Stem/Hinge Pin	403SS				403SS				403SS			403SS			
Disc	13Cr or Carbon Steel+13Cr				13Cr or Carbon Steel+13Cr				13Cr or Carbon Steel+13Cr			13Cr or Carbon Steel+13Cr			
Body Seat Ring	Carbon Steel+HF				Carbon Steel+HF				Carbon Steel+HF			Carbon Steel+HF			
Gland Packing	Flexible Graphite				Flexible Graphite										
Gasket	Refer to Page CS9				Refer to Page CS9				Refer to Page CS9			Refer to Page CS9			
Bonnet Bolt/Nut	B7/2H				B7/2H				B7/2H			B7/2H			
P-T Rating	ASME B16.34				ASME B16.34				ASME B16.34			ASME B16.34			
F-to-F Dimension	ASME B16.10				ASME B16.10				ASME B16.10			ASME B16.10			
Wall Thickness	API 623				API 623				API 600			API 594			
Approval	ISO15848-1 API 624, PED/CE TR-CU/EAC				ISO15848-1 API 624, PED/CE TR-CU/EAC				PED/CE TR-CU/EAC			PED/CE TR-CU/EAC			
Remarks									*ASME B16.47 Series B (26" & above)			Internal Hinge Pin			

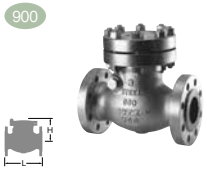
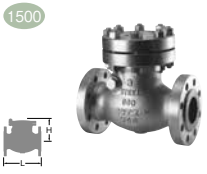
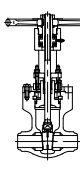
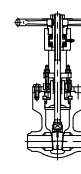
Type	Swing Check			Swing Check			Swing Check			Swing Check			
Carbon & Low Alloy Steel Valves (GGC)													
	300SCOS			300SCOHS			600SCOS			600SCOHS			
Fig	300SCOS			300SCOHS			600SCOS			600SCOHS			
End Connection	ASME B16.5 Class 300 RF*			ASME B16.5 Class 300 RF			ASME B16.5 Class 600 RF			ASME B16.5 Class 600 RF			
inch	mm	L	H	D	L	H	D	L	H	D	L	H	D
11/2	40	241	155		241	155							
2	50	267	164		267	164		292	194		292	195	
21/2	65	292	190		292	190		330	216		330	216	
3	80	318	205		318	205		356	235		356	240	
4	100	356	230		356	230		432	260		432	255	
5	125	400	250					508	293				
6	150	444	280		444	280		559	332		559	338	
8	200	533	330		533	330		660	381		660	383	
10	250	622	370		622	370		787	447		787	447	
12	300	711	415		711	415		838	518		838	508	
14	350	838	491		838	491		889	599				
16	400	864	543		864	543		991	674				
18	450	978	582					1092	694				
20	500	1016	645					1194	760				
24	600	1346	866					1397	929				
28	700	1499	930										
30	750	1594	975										
Body/Bonnet/Cover	WCB			WCB			WCB			WCB			
Stem/Hinge Pin	403SS			403SS			403SS			403SS			
Disc	13Cr or Carbon Steel+13Cr			13Cr or Carbon Steel+13Cr			13Cr or Carbon Steel+13Cr			13Cr or Carbon Steel+13Cr			
Body Seat Ring	Carbon Steel+HF			Carbon Steel+HF			Carbon Steel+HF			Carbon Steel+HF			
Gasket	Refer to Page CS9			Refer to Page CS9			Refer to Page CS9			Refer to Page CS9			
Bonnet Bolt/Nut	B7/2H			B7/2H			B7/2H			B7/2H			
P-T Rating	ASME B16.34			ASME B16.34			ASME B16.34			ASME B16.34			
F-to-F Dimension	ASME B16.10			ASME B16.10			ASME B16.10			ASME B16.10			
Wall Thickness	API 600			API 594			API 600			API 594			
Approval	PED/CE TR-CU/EAC			PED/CE TR-CU/EAC			PED/CE TR-CU/EAC			PED/CE TR-CU/EAC			
Remarks	*ASME B16.47 Series B (26" & above)			Internal Hinge Pin						Internal Hinge Pin			

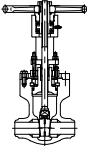
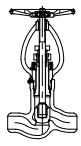
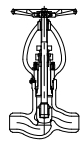
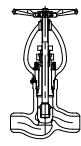
Type	Swing Check				Swing Check				Pressure Seal Bonnet Gate				Pressure Seal Bonnet Gate			
Carbon & Low Alloy Steel Valves (GGC)																
	900				1500				900				1500			
Fig	900SCOS				1500SCOS				(G-)(W)900SCLSPSY				(G-)(W)1500SCLSPSY			
End Connection	ASME B16.5 Class 900 RF				ASME B16.5 Class 1500 RF				ASME B16.25(BW) or B16.5(RF)				ASME B16.25(BW) or B16.5(RF)			
inch	mm	L	H	D	L	H	D	L	H	D	B	L	H	D	B	
2	50				368	293		TBA	TBA	TBA	TBA	TBA	TBA	TBA	TBA	
2 1/2	65				419	318		TBA	TBA	TBA	TBA	TBA	TBA	TBA	TBA	
3	80	381	296		470	339		TBA	TBA	TBA	TBA	TBA	TBA	TBA	TBA	
4	100	457	349		546	388		TBA	TBA	TBA	TBA	TBA	TBA	TBA	TBA	
6	150	610	443		705	514		TBA	TBA	TBA	TBA	TBA	TBA	TBA	TBA	
8	200	737	524		832	648		TBA	TBA	TBA	TBA	TBA	TBA	TBA	TBA	
10	250	838	619		991	736		TBA	TBA	TBA	TBA	TBA	TBA	TBA	TBA	
12	300	965	716		1130	875		TBA	TBA	TBA	TBA	TBA	TBA	TBA	TBA	
14	350	1029	794		1257	955		TBA	TBA	TBA	TBA	TBA	TBA	TBA	TBA	
16	400	1130	871		1384	1082		TBA	TBA	TBA	TBA	TBA	TBA	TBA	TBA	
18	450	1219	952					TBA	TBA	TBA	TBA	TBA	TBA	TBA	TBA	
20	500	1321	1042					TBA	TBA	TBA	TBA	TBA	TBA	TBA	TBA	
24	600							TBA	TBA	TBA	TBA	TBA	TBA	TBA	TBA	
Body/Bonnet	WCB				WCB				A105 or WCB				A105 or WCB			
Cover									403SS or OHTARON®1*				403SS or OHTARON®1*			
Disc	13Cr or Carbon Steel+13Cr				13Cr or Carbon Steel+13Cr				A105+HF or WCB+HF				A105+HF or WCB+HF			
Body Seat Ring	Carbon Steel+HF				Carbon Steel+HF				A105+HF or WCB+HF				A105+HF or WCB+HF			
Hinge Pin	403SS				403SS								Flexible Graphite			
Gasket	Refer to Page CS9				Refer to Page CS9				Flexible Graphite				Flexible Graphite			
Bonnet Bolt/Nut	B7/2H				B7/2H											
P-T Rating	ASME B16.34				ASME B16.34				ASME B16.34				ASME B16.34			
F-to-F Dimension	ASME B16.10				ASME B16.10				ASME B16.10				ASME B16.10			
Wall Thickness	API 600				API 600				ASME B16.34				ASME B16.34			
Approval	PED/CE TR-CU/EAC				PED/CE TR-CU/EAC											
Remarks									* Equivalent to SUS431				* Equivalent to SUS431			

Type	Pressure Seal Bonnet Gate				Pressure Seal Bonnet Globe				Pressure Seal Bonnet Globe				Pressure Seal Bonnet Globe				
Carbon & Low Alloy Steel Valves (GGC)																	
	2500				900				1500				2500				
Fig	(G-)(W)2500SCLSPSY				(G-)(W)900SCJSPSY				(G-)(W)1500SCJSPSY				(G-)(W)2500SCJSPSY				
End Connection	ASME B16.25(BW) or B16.5(RF)				ASME B16.25(BW) or B16.5(RF)				ASME B16.25(BW) or B16.5(RF)				ASME B16.25(BW) or B16.5(RF)				
inch	mm	L	H	D	B	L	H	D	B	L	H	D	B	L	H	D	B
2	50	TBA	TBA	TBA	TBA	TBA	TBA	TBA	TBA	TBA	TBA	TBA	TBA	TBA	TBA	TBA	TBA
2 1/2	65	TBA	TBA	TBA	TBA	TBA	TBA	TBA	TBA	TBA	TBA	TBA	TBA	TBA	TBA	TBA	TBA
3	80	TBA	TBA	TBA	TBA	TBA	TBA	TBA	TBA	TBA	TBA	TBA	TBA	TBA	TBA	TBA	TBA
4	100	TBA	TBA	TBA	TBA	TBA	TBA	TBA	TBA	TBA	TBA	TBA	TBA	TBA	TBA	TBA	TBA
6	150	TBA	TBA	TBA	TBA	TBA	TBA	TBA	TBA	TBA	TBA	TBA	TBA	TBA	TBA	TBA	TBA
8	200	TBA	TBA	TBA	TBA	TBA	TBA	TBA	TBA	TBA	TBA	TBA	TBA	TBA	TBA	TBA	TBA
10	250	TBA	TBA	TBA	TBA	TBA	TBA	TBA	TBA	TBA	TBA	TBA	TBA	TBA	TBA	TBA	TBA
12	300	TBA	TBA	TBA	TBA	TBA	TBA	TBA	TBA	TBA	TBA	TBA	TBA	TBA	TBA	TBA	TBA
14	350	TBA	TBA	TBA	TBA	TBA	TBA	TBA	TBA	TBA	TBA	TBA	TBA	TBA	TBA	TBA	TBA
16	400	TBA	TBA	TBA	TBA												
18	450	TBA	TBA	TBA	TBA												
20	500	TBA	TBA	TBA	TBA												
24	600	TBA	TBA	TBA	TBA												
Body/Bonnet	A105 or WCB				A105 or WCB				A105 or WCB				A105 or WCB				
Stem	403SS or OHTARON®1*				403SS or OHTARON®1*				403SS or OHTARON®1*				403SS or OHTARON®1*				
Disc	A105+HF or WCB+HF				A105+HF or WCB+HF				A105+HF or WCB+HF				A105+HF or WCB+HF				
Body Seat Ring	A105+HF or WCB+HF				A105+HF or WCB+HF				A105+HF or WCB+HF				A105+HF or WCB+HF				
Gland Packing	Flexible Graphite				Flexible Graphite				Flexible Graphite				Flexible Graphite				
Gasket	Flexible Graphite				Flexible Graphite				Flexible Graphite				Flexible Graphite				
P-T Rating	ASME B16.34				ASME B16.34				ASME B16.34				ASME B16.34				
F-to-F Dimension	ASME B16.10				ASME B16.10				ASME B16.10				ASME B16.10				
Wall Thickness	ASME B16.34				ASME B16.34				ASME B16.34				ASME B16.34				
Remarks	* Equivalent to SUS431				* Equivalent to SUS431				* Equivalent to SUS431				* Equivalent to SUS431				

Type		Pressure Seal Bonnet Check			Pressure Seal Bonnet Check			Pressure Seal Bonnet Check		
Carbon & Low Alloy Steel Valves (GGC)		900 PSB 			1500 PSB 			2500 PSB 		
		(W)900SCOSPSY			(W)1500SCOSPSY			(W)2500SCOSPSY		
Fig		(W)900SCOSPSY			(W)1500SCOSPSY			(W)2500SCOSPSY		
End Connection		ASME B16.25(BW) or B16.5(RF)			ASME B16.25(BW) or B16.5(RF)			ASME B16.25(BW) or B16.5(RF)		
inch	mm	L	H	D	L	H	D	L	H	D
2	50	TBA	TBA	TBA	TBA	TBA	TBA	TBA	TBA	TBA
2 1/2	65	TBA	TBA	TBA	TBA	TBA	TBA	TBA	TBA	TBA
3	80	TBA	TBA	TBA	TBA	TBA	TBA	TBA	TBA	TBA
4	100	TBA	TBA	TBA	TBA	TBA	TBA	TBA	TBA	TBA
6	150	TBA	TBA	TBA	TBA	TBA	TBA	TBA	TBA	TBA
8	200	TBA	TBA	TBA	TBA	TBA	TBA	TBA	TBA	TBA
10	250	TBA	TBA	TBA	TBA	TBA	TBA	TBA	TBA	TBA
12	300	TBA	TBA	TBA	TBA	TBA	TBA	TBA	TBA	TBA
14	350	TBA	TBA	TBA	TBA	TBA	TBA	TBA	TBA	TBA
16	400	TBA	TBA	TBA	TBA	TBA	TBA	TBA	TBA	TBA
18	450	TBA	TBA	TBA	TBA	TBA	TBA	TBA	TBA	TBA
20	500	TBA	TBA	TBA	TBA	TBA	TBA	TBA	TBA	TBA
24	600	TBA	TBA	TBA	TBA	TBA	TBA	TBA	TBA	TBA
Body		WCB			WCB			WCB		
Bonnet/Cover		A105			A105			A105		
Hinge Pin		403SS or OHTARON® 1*			403SS or OHTARON® 1*			403SS or OHTARON® 1*		
Disc		A105+HF or F11+HF			A105+HF or F11+HF			A105+HF or F11+HF		
Body Seat Ring		A105+HF or F11+HF			A105+HF or F11+HF			A105+HF or F11+HF		
Gasket		Flexible Graphite			Flexible Graphite			Flexible Graphite		
P-T Rating		ASME B16.34			ASME B16.34			ASME B16.34		
F-to-F Dimension		ASME B16.10			ASME B16.10			ASME B16.10		
Wall Thickness		ASME B16.34			ASME B16.34			ASME B16.34		
Remarks		* Equivalent to SUS431			* Equivalent to SUS431			* Equivalent to SUS431		

General Design Specifications

Items	American Standard		British Standard
	Bolted Bonnet	Pressure Seal	
Shell Wall Thickness and General Valve Design	API 600 API 623 API 594	ASME B 16.34	BS/ISO 10434 (Gate Valve) BS 1873 (Globe Valve) BS 1868 (Check Valve)
Pressure-Temperature Rating	ASME B16.34		BS EN 1759-1
Face to Face Dimensions End to End Dimensions	ASME B16.10		BS EN 558-1
End Flange Dimensions Gasket Contact Facing	ASME B16.5*		BS EN 1759-1
Weld End Dimensions	ASME B16.25		BS/ISO 10434 (Gate Valve) BS 1873 (Globe Valve) BS 1868 (Check Valve)

* End Flange Dimensions of Nominal Size 22 is MSS SP-44 and ASME B16.47 Series B for Nominal Size 26 and larger.

Valve Shell Materials

Besides the standard material of ASTM A216 WCB, KITZ cast steel valves are optionally available in materials listed below.

ASTM Specification	Material Designation	Working Temperature ^{*1} °F (°C)	KITZ Code
A216 WCB / A216 WCC	Carbon Steel	1000 (538) Maximum	-
A217 WC1	C-1/2 Mo		1C
A217 WC6	11/4 Cr-1/2 Mo	1100 (593) Maximum	6C
A217 WC9	21/4 Cr-1Mo		9C
A217 C5	5Cr-1/2 Mo	1200 (649) Maximum	5C
A217 C12	9Cr-1Mo		12C
A352 LCB	Carbon Steel	-50 (-46) Minimum	BL
A352 LCC	Carbon Steel		CL
A352 LC1	C-1/2 Mo	-75 (-59) Minimum	1L
A352 LC2	21/2 Ni -100	-100 (-73) Minimum	2L
A352 LC3	31/2 Ni -150	-150 (-101) Minimum	3L

For ASTM A351 Austenitic Stainless Steel, refer to Stainless Steel Section (SS).

*1 Refer to ASME B16.34 for details of ASTM A216, A217 and A352 Pressure-temperature ratings. (See page CS15 for A216 and A217)

Minimum Working Temperature of ASTM A352 is in accordance with ASME B31.3.

*2 Maximum and minimum temperature of the valve will vary, depending on the pressure class and temperature range of the seal material.

KITZ Low Temperature Service Valves

KITZ Corporation offers Class 150, 300 and 600 API 600 design low alloy steel valves for low temperature service down to -150°F (-101°C). Detailed design information is available on request.

Valve Trim Materials

API 600/623/594 specifies the following valve components as valve trim:

Description	Gate Valve	Globe Valve	Check Valve
Disc seat Surface	●	●	●
Body seat Surface	●	●	●
Bonnet Bush (Backseat)	●	●	-
Stem	●	●	-
Others	Internal Small Parts	Lock Nut	Hinge Pin
Specified by	API 600	API 623	API 594

Disc Seat and Body Seat

Following trims specified in API 600 Table 8 are available with KITZ, either as standard or an option. Composition of combination in trims, which employs different seating surface materials for disc seat and body seat, shall be arranged at manufacturer's discretion, unless specified in advance.

Combination Number	Material Description	Brinell Hardness
5.	HF / HF	350HB min.
8.	13Cr / HF	250HB min. / 350HB min.
11.*	Ni-Cu alloy (Monel) / HF	Not specified / 350HB min.
12.*	18Cr-8Ni-Mo (316) / HF	Not specified / 350HB min.
14.*	19Cr-29Ni (Alloy 20) / HF	Not specified / 350HB min.

*Optionally available.

HF: Co-Cr-W Alloy (Stellite No.6) deposited.

Stems and Bonnet Bushing (Backseat Bushing)

ASTM A182 (F6a) is our standard material for stems and bonnet bushing. Other materials including ASTM A182 (F304), A182 (F316), Monel and Alloy 20 are available on your specific request.

Body Seat Rings

Body seat rings of KITZ cast steel valves are mounted on the valve body by seal welding as illustrated in below typical examples of gate valves. Unless specifically requested in advance, mounting of body seat rings shall be made at manufacturer's discretion. Please specify method of mounting, by mentioning adequate KITZ product code in your purchase orders.

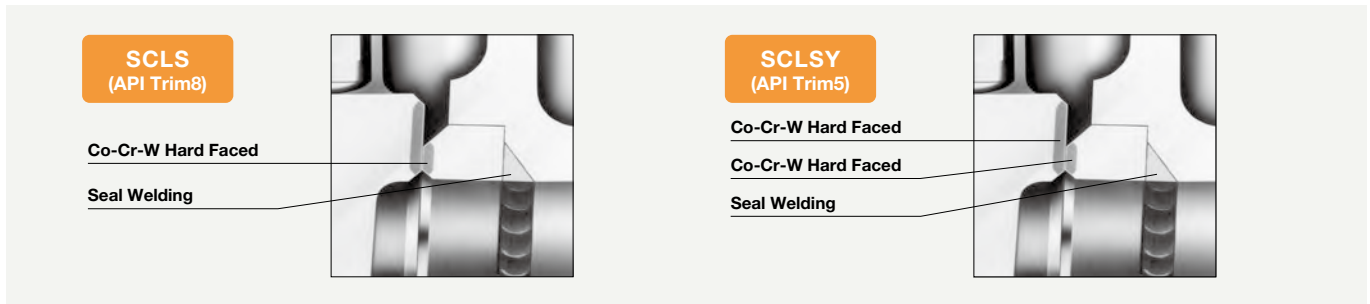

For standard shell material in KITZ cast steel valves made of ASTM A216 WCB, disc seats and body seat rings are provided to below. (Refer to Page CS2 for Product Coding)

KITZ Product Code	Standard Disc Seat	Standard Body Seat	Mounting of Body Seat Rings
SCLS (Gate) SCJS (Globe) SCOS (Check) SCOHS (Check)	F6a or WCB + 13Cr or A105 + 13Cr or CA15	A105 + HF* or A106 Gr. B + HF* or AISI 1022 + HF* or Direct HF**	Seal Welded or Direct HF**
SCLSY (Gate) SCJSY (Globe) SCOSY (Check) SCOHSY (Check)	A105 + HF* or WCB + HF* or CA15 + HF*	A105 + HF* or A106 Gr. B + HF* or AISI 1022 + HF* or Direct HF**	Seal Welded or Direct HF**

* Co-Cr-W Alloy deposited for hard facing.

** Co-Cr-W Alloy is directly deposited on valve body for hard facing.

KITZ Product Code 900SCJS, 900SCJSY, 1500SCJS and 1500SCJSY globe valves employ this hard facing.

Bonnet Gasket Materials

Depending on class ratings and servicing conditions, following gasket materials are available for body/bonnet flange gaskets of KITZ cast steel valves. Please specify gasket material required in purchase order.

Gasket Material	Class				
	150	300	600	900	1500
Corrugated Metal with Flexible Graphite	●				
Ring Joint Material			●	●	●
Spiral Wound Metal, Flexible Graphite Filled		●	●*		
Stainless Steel Inserted Flexible Graphite	●				

Note: Refer to Page CS11 for bonnet gaskets used for KITZ low emission service valves.

*600 SCOHS: Spiral wound metal, graphite filled only.

Contact Face of Flanges

ASME B16.5 specifies several different types of contact face of flanges as illustrated below. Among them, KITZ cast steel valves employ 0.06 Raised Face (RF) for Class 150 and 300, and 0.25 Raised Face (RF) for higher pressure classes with an optional employment of ring-joint contact.

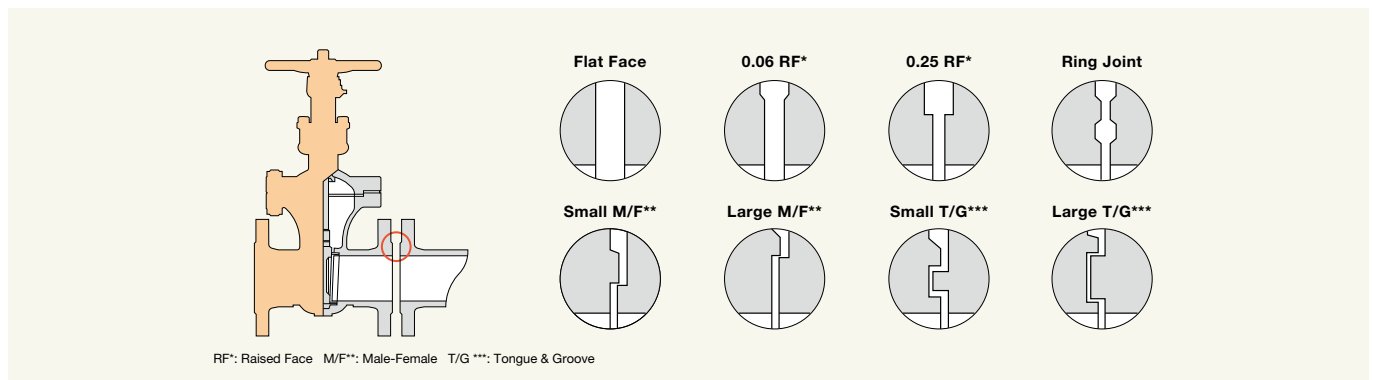

Gasket contact surface finish of end flanges as well as body-bonnet flanges depends on the materials selected for flange gaskets.

NACE Valves

For sour gas services and other hydrogen sulfide bearing hydrocarbon fluids, KITZ offers NACE valves made of component materials specially heat-treated and hardness-controlled to conform with NACE MR0103, KITZ Standard, or optionally NACE MR0175 Standard.

Typical NACE material configuration is shown below for KITZ cast steel gate valves.

KITZ NACE steel valves are available only as a specified option.

Note: NACE hardness requirements conflicts with the valve trim.

Valve Parts	ASTM Specification	NACE Hardness
Body/bonnet	A216 WCB	≤ HRC 22 (237 HB)
Disc	A216 WCB or AISI Type 410 or A217 CA15	
Disc seat	*13Cr deposit or AISI Type 410	
Gland	*AISI Type 410	
Stem		
Bonnet bushing		
Body seat surface	HF**	≥ 350 HB
Bonnet bolts	A193 B7	-
	A193 B7M***	≤ HRC 22
Bonnet nuts	A194 2H	-
	A194 2HM***	≤ HRC 22

*Double tempered. (Three step process)

**Co-Cr-W Alloy deposited for hard facing.

*** General requirements to conform with NACE MR0175 Standard.

Users shall be aware its necessity to lower equipment pressure rating when using SSC-Resistant bolts and nuts.

Please contact KITZ for more information.

Inspection and Warranty Policy of KITZ Corporation

Every piece of KITZ cast carbon and low alloy steel valves is subjected to 100% pressure test, according to API 598 requirements. Manufacturer's material test reports and inspection certificates are available on request, while each valve is guaranteed for 12 months after installation in service, but not exceeding 18 months after shipment from the factories of KITZ Corporation.

Various tests and inspections of valves made by KITZ Corporation includes below. Unless otherwise specified, all KITZ cast steel valves shall be subjected to these tests or inspection methods and evaluation criteria.

Test/Inspection Item	Method	Evaluation
Chemical Composition Analysis		Relevant ASTM Stds.
Mechanical Property Test	ASTM A370 / E8	Relevant ASTM Stds.
Pressure Tests	API 598	API 598
Radiographic Inspection	ASTM E94	ASME B16.34
Wet Magnetic Particle Inspection	ASTM E709	
Liquid Penetrant Inspection	ASTM E165	
Low Temperature Impact Test	ASTM A370 / E23	ASTM A352
Dimensional Inspection		Relevant Valve Stds.
Valve Inspection		MSS SP-55
Emission Test*	EPA Method 21 and KITZ Std.	KITZ Std.

*Applicable to low emission service valves.

Typical KITZ Inspection Flow

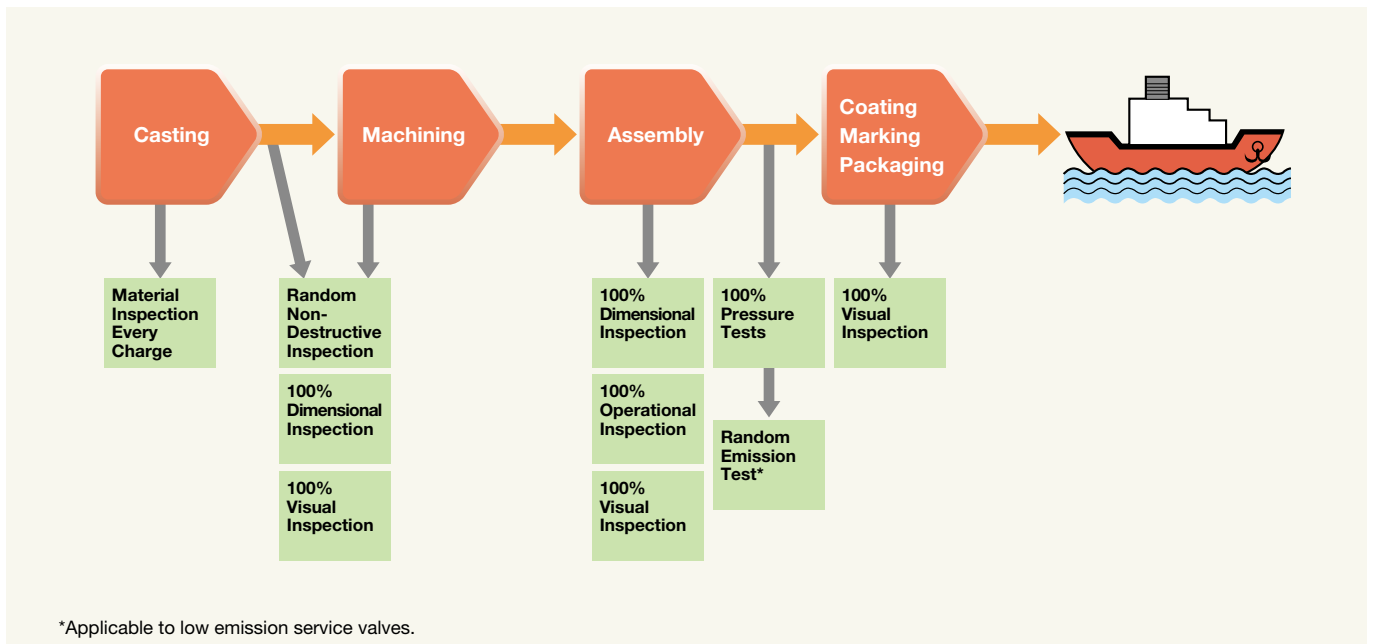

KITZ Low Emission Service Valves

In the United States, the Federal Clean Air Act was dramatically amended in 1990, to realize the new environmental protection policy of 95% reduction in fugitive emission or leak levels of toxic gases and chemicals from plant equipment. Promulgated in April, 1994, the new law requires all plants handling toxic gas specified by the Environmental Protection Agency, to periodically monitor their plant equipment for detection of leaks exceeding 500 ppm, and repair or replace all defective parts immediately. California has exceeded the Federal Law with State Regulation requiring 100 ppm maximum leak level for astonishing 99% reduction of such environmental pollution for the Northern California Region after 1997.

Our low emission valves, the proud fruits of several years of trial and error at our laboratory, are designed, engineered, manufactured and tested to now meet the 100 ppm maximum emission level. This is the standard specification in North America for KITZ flanged and butt-welding end carbon or low alloy steel valves rated Class 150, 300 and 600. In other markets, all these low emission valves are optionally available. Major design considerations for having upgraded our standard valves to the low emission performers are introduced below.

Gland Packing

KITZ's original "SEALEVER[®]" flexible graphite packing set, consisting of 4 dieformed flexible graphite rings* and 2 braided flexible graphite rings, combined with a spacer bush for Class 300 and above rated valves.

*US Patent No. 5522603 & 5573253. Other patents registered or pending worldwide.

Bonnet Gaskets (Including Check Valve Cover Gaskets)

Class 150 : Corrugated metal with flexible graphite and permeation protective barrier for low emission service

Class 300 : Spiral wound (flexible graphite filler and stainless steel hoop) with a stainless steel inner ring

Class 600 & above : Ring joint metal gasket

*Class 600 SCOHS: Spiral wound. (flexible graphite filler and stainless steel hoop)

Diametrical Interface Clearance

20 to 32 mils (0.5 to 0.8 mm) : Stem to gland

20 to 32 mils (0.5 to 0.8 mm) : Stem to bonnet bushing

4 to 12 mils (0.1 to 0.3 mm) : Gland to stuffing boxes

Stem

16 to 32 RMS surface finish. Straightness and roundness are precisely controlled according to KITZ design and manufacturing standards.

Stuffing Box

Maximum 125 RMS surface finish. Cylindricity and verticality are precisely controlled according to KITZ design and manufacturing standards.

Plug Gaskets for Check Valves

Class 150/300 : Flexible graphite sheet with stainless steel insert and permeation protective barrier.

Class 600 & above : Spiral wound metal with flexible graphite filled

*Except for the 150-600 SCOHS.

Product Identification

Stainless steel ID plate with the letters "LOW EMISSION" in orange is welded on the bonnet flanges.

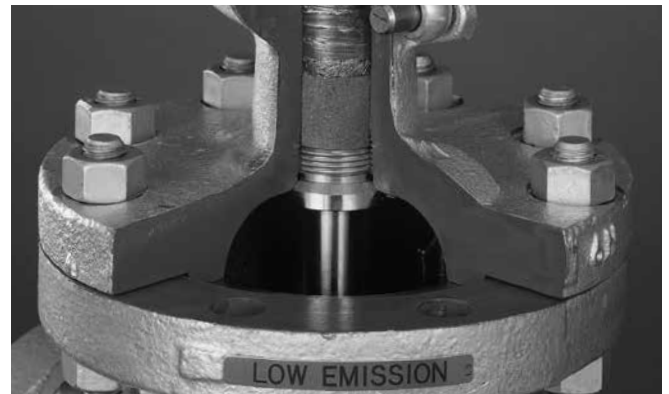

YRT Emission Test Results

In addition to our in-house lab tests and certifications by Lloyd's Register of Shipping, a third-party performance test was carried out on a KITZ nominal size 6 Class 300 gate valve at Yarmouth Research and Technology, Maine, USA, according to one user's testing specifications. The test conditions included an unprecedented 3500 cycle operation of a 99% methane pressurized valve through thermal cycles at 350°F (177°C), with the valve stem positioned horizontally to the ground, and the leak level was monitored at every 100 cycles, from an aluminum foil housing sealed the valve gland area. In spite of these severe test conditions, the results were in close agreement with findings from the tests made at our laboratory over the last several years.

Design Features of KITZ Gate Valve Wedges (Discs)

Among four different shapes of wedge gates recognized by API 600 Paragraph 5.6.1.1 and 5.6.1.2, KITZ has adopted solid wedges for smaller valves such as nominal size 2 to 4 of Class 900/1500 gate valves, and flexible wedges for all other sizes of all pressure classes.

H-shaped flexible wedges are featured with mechanical flexibility to adjust its own shape following the shape of body seats for tightly secured mutual contact. This is particularly important when larger gate valves are served in extremely high pressure and temperature, where temporary deformation of the valve body always occurs. Operational torque is smaller, seat wear is less and valve closure is tighter when H-shaped flexible wedges are adopted.

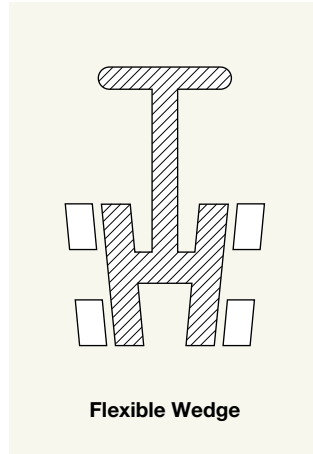
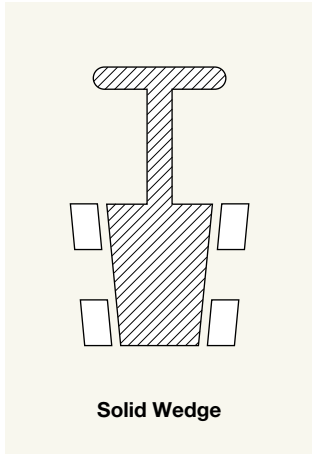

Solidly designed KITZ wedge gates are forged or cast solid, single piece of steel without any welding work. Specially heat-treated wedges are firmly coupled with integral T-head of the valve stems, which are also ruggedly designed and specially heat-treated for the highest possible durability of stem to wedge connection. API 600 Paragraph 5.8.7 particularly emphasizes the importance of the mechanical strength of this connection.

As another unique feature, KITZ wedge gates are designed for always accurately maintained concentricity and carefully lapped for leakfree contact.



Side View



Front View



Stem-to-Wedge Connection

Design

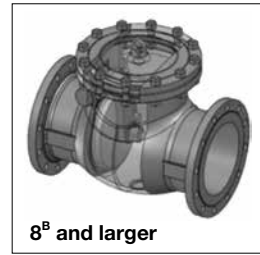
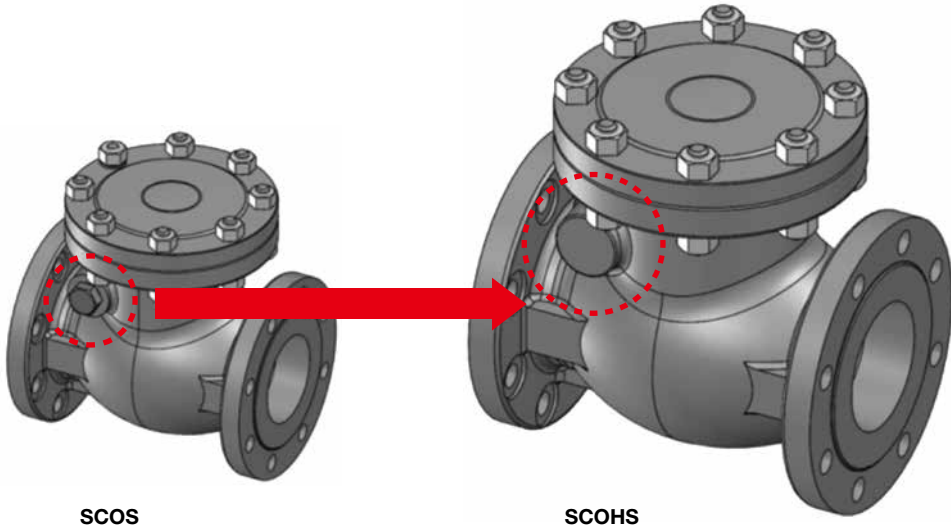

Features

- Designed according to API594 (2017) (except 11/2^B)
- No risk of leakage from hinge pin plug
- Anti-Rotation disc design
- Same F to F dimension with current KITZ check valves
- Same flow rate as SCOS

Body Disc Connection

Disc Hanger Type

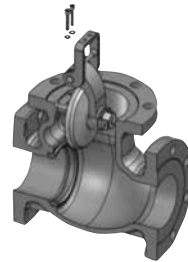

6^B and smaller

Body Fix Type

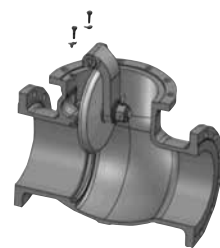

8^B and larger

Pressure Seal Bonnet Valve

Gate Valve

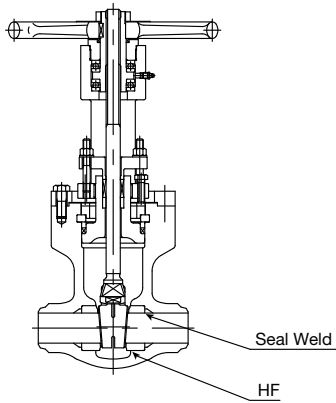

Globe Valve

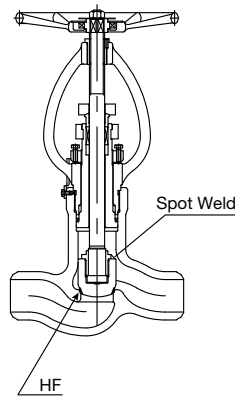

Check Valve

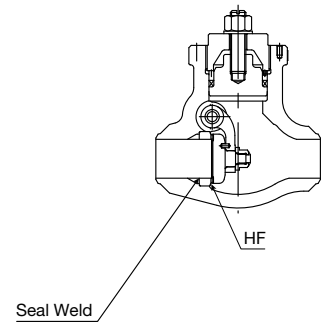

Parts	Materials
Body	A216 Gr.WCB
Bonnet	Up to 200A: A105 250A & over: A216 Gr.WCB
Stem	SUS403 or OHTARON®1
Disc	Up to 250A: A105+HF* 300A & over: A216 Gr.WCB+HF*
Gland Packing	Flexible Graphite
Gasket	Flexible Graphite
Body Seat Ring	A105+HF*
Handwheel	Ductile Iron

Parts	Materials
Body	A216 Gr.WCB+ HF*
Bonnet	A105
Stem	OHTARON®1
Disc	A182 F11+ HF*
Packing	Flexible Graphite
Gasket	Flexible Graphite
Handwheel	SCPH2+SF440A

Parts	Materials
Body	A216 Gr.WCB
Cover	A105
Disc	Up to 125A: 105+ HF* 150A and Over: A182 F11+ HF*
Gasket	Flexible Graphite
Body Seat Ring	Up to 125A A105+ HF* 150A and over: A182 F11+ HF*

*HF: Hard facing with Co-Cr-W alloy
OHTARON® is a registered trademark of TVE Co.,Ltd.

Product Range

Fig.	Nominal Size	DN	NPS	Valve Type	(mm)													
					50	65	80	100	150	200	250	300	350	400	450	500	650	
					2	2½	3	4	6	8	10	12	14	16	18	20	24	
900SCLSPSY				Gate	○	○	○	○	○	○	○	○	○	○	○	○	○	
1500SCLSPSY					○	○	○	○	○	○	○	○	○	○	○	○	○	○
2500SCLSPSY					○	○	○	○	○	○	○	○	○	○	○	○	○	○
900SCJSPSY				Globe	○	○	○	○	○	○	○	○						
1500SCJSPSY					○	○	○	○	○	○	○	○						
2500SCJSPSY					○	○	○	○	○	○	○	○						
900SCOSPSY				Check	○	○	○	○	○	○	○	○	○	○	○	○	○	
1500SCOSPSY					○	○	○	○	○	○	○	○	○	○	○	○	○	
2500SCOSPSY					○	○	○	○	○	○	○	○	○	○	○	○	○	

For specification of gear operation, please contact KITZ for more information.

■ Design Standard: ASME B16.34
P-T rating: ASME B16.34
■ In case of gear operation, "G-" will be added in front of product codes

**Pressure - Temperature Ratings <For Reference Only>
Valves - Flanged and Welding End : Standard Class**

ASTM Material Standard-to ASME B16.34 2013

Temperature		Working Pressures by Class, psig														
		Class 150					Class 300					Class 600				
°F	°C	WCB (a)	WC6 (b)	C5 (c)	C12 (c)	LCC (d)	WCB (a)	WC6 (b)	C5 (c)	C12 (c)	LCC (d)	WCB (a)	WC6 (b)	C5 (c)	C12 (c)	LCC (d)
-20 to 100	-29 to 38	285	290	290	290	290	740	750	750	750	750	1,480	1,500	1,500	1,500	1,500
200	93	260	260	260	260	260	680	750	750	750	750	1,360	1,500	1,500	1,500	1,500
300	149	230	230	230	230	230	655	720	730	730	730	1,310	1,445	1,455	1,455	1,455
400	204	200	200	200	200	200	635	695	705	705	705	1,265	1,385	1,410	1,410	1,405
500	260	170	170	170	170	170	605	665	665	665	665	1,205	1,330	1,330	1,330	1,330
600	316	140	140	140	140	140	570	605	605	605	605	1,135	1,210	1,210	1,210	1,210
650	343	125	125	125	125	125	550	590	590	590	590	1,100	1,175	1,175	1,175	1,175
700	371	110	110	110	110	110	530	570	570	570	555	1,060	1,135	1,135	1,135	1,110
750	399	95	95	95	95	95	505	530	530	530	505	1,015	1,065	1,065	1,065	1,015
800	427	80	80	80	80	80	410	510	510	510	410	825	1,015	1,015	1,015	825
850	454	65	65	65	65	65	320	485	485	485	320	640	975	975	975	640
900	482	50	50	50	50	50	230	450	375	450	225	460	900	745	900	445
950	510	35	35	35	35	35	135	320	275	375	135	275	640	550	755	275
1000	538	20	20	20	20	20	85	215	200	255	85	170	430	400	505	170
1050	566		20	20	20			145	145	170			290	290	345	
1100	593		20	20	20			95	100	115			190	200	225	
1150	621		20	20	20			65	60	75			130	125	150	
1200	649		15	15	20			40	35	50			80	70	105	

Temperature		Working Pressures by Class, psig														
		Class 900					Class 1500					Class 2500				
°F	°C	WCB (a)	WC6 (b)	C5 (c)	C12 (c)	LCC (d)	WCB (a)	WC6 (b)	C5 (c)	C12 (c)	LCC (d)	WCB (a)	WC6 (b)	C5 (c)	C12 (c)	LCC (d)
-20 to 100	-29 to 38	2,220	2,250	2,250	2,250	2,250	3,705	3,750	3,750	3,750	3,750	6,170	6,250	6,250	6,250	6,250
200	93	2,035	2,250	2,250	2,250	2,250	3,395	3,750	3,750	3,750	3,750	5,655	6,250	6,250	6,250	6,250
300	149	1,965	2,165	2,185	2,185	2,185	3,270	3,610	3,640	3,640	3,640	5,450	6,015	6,070	6,070	6,070
400	204	1,900	2,080	2,115	2,115	2,110	3,170	3,465	3,530	3,530	3,520	5,280	5,775	5,880	5,880	5,865
500	260	1,810	1,995	1,995	1,995	1,995	3,015	3,325	3,325	3,325	3,325	5,025	5,540	5,540	5,540	5,540
600	316	1,705	1,815	1,815	1,815	1,815	2,840	3,025	3,025	3,025	3,025	4,730	5,040	5,040	5,040	5,040
650	343	1,650	1,765	1,765	1,765	1,765	2,745	2,940	2,940	2,940	2,940	4,575	4,905	4,905	4,905	4,905
700	371	1,590	1,705	1,705	1,705	1,665	2,665	2,840	2,840	2,840	2,775	4,425	4,730	4,730	4,730	4,630
750	399	1,520	1,595	1,595	1,595	1,520	2,535	2,660	2,660	2,660	2,535	4,230	4,430	4,430	4,430	4,230
800	427	1,235	1,525	1,525	1,525	1,235	2,055	2,540	2,540	2,540	2,055	3,430	4,230	4,230	4,230	3,430
850	454	955	1,460	1,460	1,460	955	1,595	2,435	2,435	2,435	1,595	2,655	4,060	4,060	4,060	2,655
900	482	690	1,350	1,120	1,350	670	1,150	2,245	1,870	2,245	1,115	1,915	3,745	3,115	3,745	1,855
950	510	410	955	825	1,130	410	685	1,595	1,370	1,885	685	1,145	2,655	2,285	3,145	1,145
1000	538	255	650	595	760	255	430	1,080	995	1,270	430	715	1,800	1,655	2,115	715
1050	566		430	430	515			720	720	855			1,200	1,200	1,430	
1100	593		290	300	340			480	495	565			800	830	945	
1150	621		195	185	225			325	310	375			545	515	630	
1200	649		125	105	155			205	170	255			345	285	430	

- (a) Upon prolonged exposure to temperatures above 800°F, the carbide phase of steel may be converted to graphite. Permissible, but not recommended for prolonged use above 800°F
- (b) Use normalized and tempered material only. Permissible, but not recommended for prolonged use above 1100°F
- (c) Use normalized and tempered material only.
- (d) Not to be used over 650°F.

CS
Carbon Steel